

Allen Carton Coders

Carton & Sleeve Coders for the Food, Pharmaceutical, Cosmetics and Chemical Industries

Allen Carton Coders offer fast and accurate off line carton, sleeve and blister card coding. With quick and simple set up, easy product changeovers and low maintenance requirements, the machines give you increased uptime and product flexibility allowing you to react quickly to the needs of your production schedule.

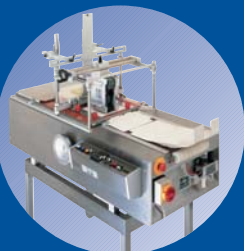

A range of semi and fully automatic offline coding systems giving product flexibility that allows you to meet your production needs



Allen Coding Carton Coders are offline machines designed for the application of variable product data including expiry dates, barcodes and real time information to an extensive variety of cartons, sleeves and cards. All systems are easy to use, making it easy to train staff and handle multiple product changes on a daily basis. There are three different machines available depending on your coding requirements.

Allen 5SA

A semi automatic machine available with Allen Coding Hot Foil or Thermal Transfer Coders. The coders are fitted in a portable bench mounted frame and are operated using a foot or hand switch. Ideal for short production runs and special products, the versatility of the Allen 5SA unit is endless. They can be operated effectively using minimal space and can cater for a vast range of packaging materials.

Allen 4ACC

Fitted with your choice of Allen Coding Compact Hot Foil Coder giving a choice of print areas to suit your needs. The Allen 4ACC is a free standing unit designed for efficient handling of normally difficult raised end flaps. A simple hopper assembly allows for quick and easy set up and changeovers.

Allen BDS

This versatile system transports the packaging material in intermittent motion. Its modular design also allows for vacuum and multi station variants giving complete handling and coding flexibility. Available with a choice of coding units to suit your requirements, allowing you to print batch, expiry and production codes, barcodes, real time, logos and autocodes.



Allen 5SA

Overview

Allen Coding Hot Foil and Thermal Transfer Coding machines are ideally suited to overprint directly onto a wide range of substratum. The hot foil Allen 5SA has a maximum print area of 78 mm to 45 mm and comes with a comprehensive range of type and typeholder options, to suit individual requirements. The thermal transfer Allen 5SA has a maximum of 107 mm by 90 mm and can produce a vast range of formats at the touch of a button. It can produce barcodes, graphics, logos, product information and real time.

Features

- Choice of thermal or hot foil coding
- Ideal for cartons and sleeves
- Exceptionally high print quality
- Simple set up and operation
- Comprehensive range of clip-in typeholders
- Rapid foil replacement
- Reliable and robust



Allen 4ACC

Overview

Product is rapidly passed across the table-top surface using the very effective pusher plate system. This positions the carton under the coder where it can be printed with a variety of formats before passing onto the outfeed system where it can be collated.

The machine is equipped with a low foil warning, foil run out alarm and a preset batch counter, which can be set to count up or down for 10,000 items, eliminates wastage by automatically shutting off the machine after coding the required number of cartons. The machine allows a coder to be fitted with a maximum print area of up to 78 mm by 45 mm. The high reliability of the machine is attained by effective design and engineering. Its record of reliability speaks for itself. A fully adjustable height setting for the outfeed mechanism allows throughput of a variety of carton thickness and the unit is designed for efficient handling of normally difficult raised end-flaps. Because it is installed offline, the Allen 4ACC can be left to run with minimal supervision.

Features

- Easy carton loading
- Ideal for cartons and sleeves
- Exceptionally high print quality
- Simple set up and operation
- Comprehensive range of clip-in typeholders
- Rapid foil replacement
- Reliable and robust
- Crash lock kit available
- Code readers, blob detectors, vision inspection and character readers can be fitted
- Built on castors for easy transportation to different production areas



Allen BDS

Overview

Compact and robust, the Allen BDS can handle cartons, sleeves, blister cards, leaflets and cut labels including product with complex shapes. Product is transported from the hopper to the printhead by a belt drive or vacuum drive giving excellent print registration. Rapid product changes can be accomplished quickly and easily with its adjustable feeder and position indicators. Parameters such as speed, index length and batch quantity are easily changed via the keypad Bulk infeed conveyors are available, allowing increased 'uptime'. Manufactured from stainless steel and anodised aluminium, meeting the demands of food and pharmaceutical industries.

Features

- Choice of thermal transfer or hot foil coding
- High product throughput
- Batch counter
- Low foil warning
- Vacuum option
- Multiple printheads fitted
- Code readers, blob detectors, vision inspection and character readers can be fitted
- Product collator options including shingling conveyor
- Bag feeding model for plastic bags and flexible packaging

Allen 5SA dimensional diagram

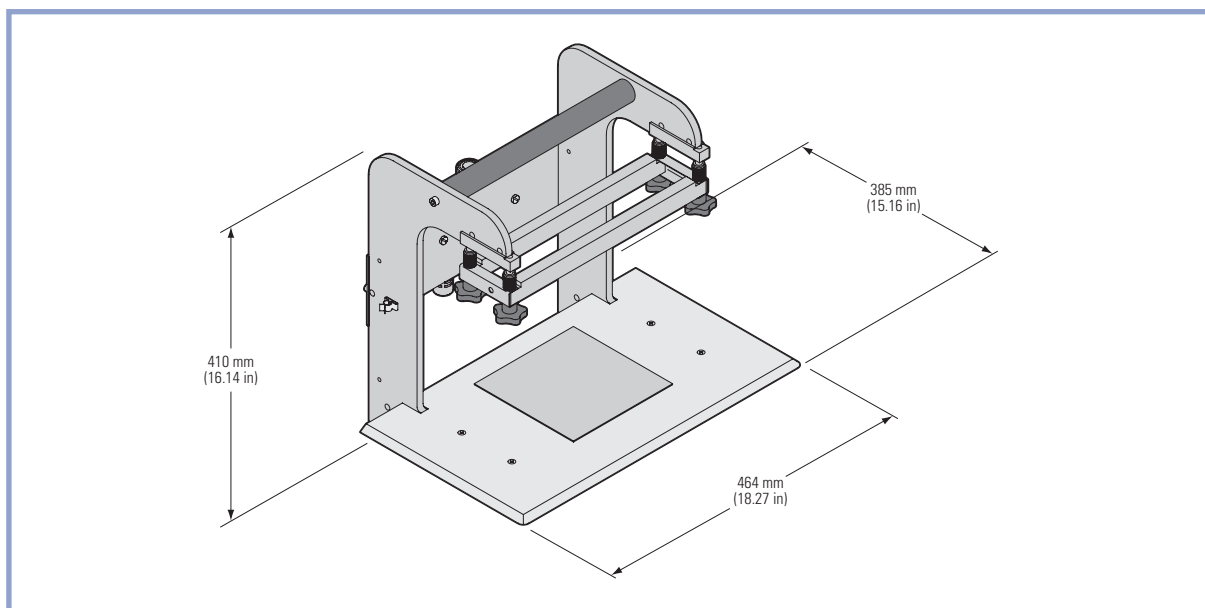

Allen 4ACC dimensional diagram

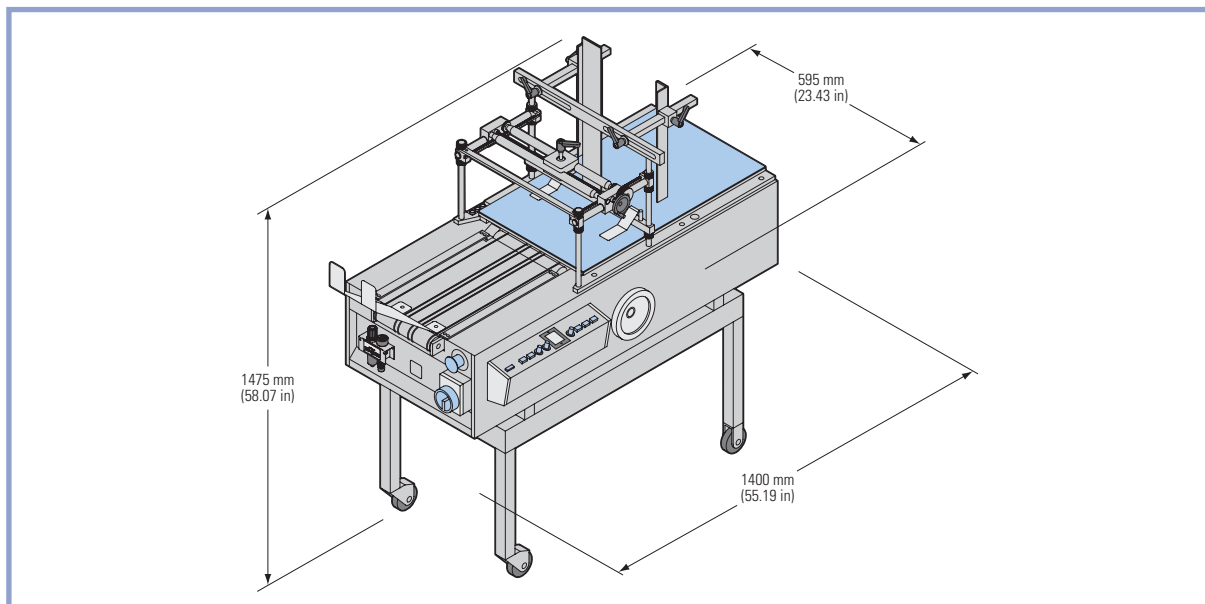

Allen BDS dimensional diagram

