



A DIVISION OF ITW

WIRE FIXTURES – WFC fixtures are designed to provide both a single marking area for continuous incremental marking, and side by side marking areas for simultaneous end marking applications. The configuration may be changed as illustrated on opposite page. Fixture size is determined by taking a loose micrometer reading of wire O.D. Select the fixture that equals or is slightly larger than your measurement.

WFC Series	Wire O.D.
WireFixtures	Range
WFC-035	0.035"-0.032"
WFC-038	0.038"-0.035"
WFC-041	0.041"-0.038"
WCF-044	0.044"-0.041"
WFC-048	0.048"- 0.044"
WFC-052	0.052" - 0.048"
WFC-056	0.056" - 0.052"
WFC-060	0.060" - 0.056"
WFC-064	0.064" - 0.060"
WFC-068	0.068" - 0.064"
WFC-072	0.072" - 0.068"
WFC-076	0.076" - 0.072"
WFC-080	0.080" - 0.076"
WFC-085	0.085" - 0.080"
WFC-090	0.090" - 0.085"
WFC-095	0.095" - 0.090"
WFC-100	0.100"-0.095"
WFC-105	0.105" -0.100"
WFC-111	0.111" -0.105"
WFC-117	0.117" - 0.111"
WFC-123	0.123"-0.117"
WFC-130	0.130" -0.123"
WFC-137	0.137" -0.130"
WFC-144	0.144"-0.137"
WFC-152	0.152" -0.144"
WFC-160	0.160"-0.152"
WFC-168	0.168"-0.160"
WFC-177	0.177"-0.168"
WFC-186	0.186"-0.177"
WFC-195	0.195"-0.186"
WFC-205	0.205" -0.195"
WFC-215	0.215"-0.205"
WFC-226	0.226"-0.215"
WFC-238	0.238" - 0.226"
WFC-250	0.250" - 0.238"

2538 Wisconsin Avenue
Downers Grove, IL 60515 USA
www.itwnorwood.com
info@itwnorwood.com

Phone: 800-626-3464, 630-968-0646
Fax: 630-968-7672

KINGSLEY MACHINE CO.
PART No. WFC-XXX
WIRE FIXTURE CONFIGURATION

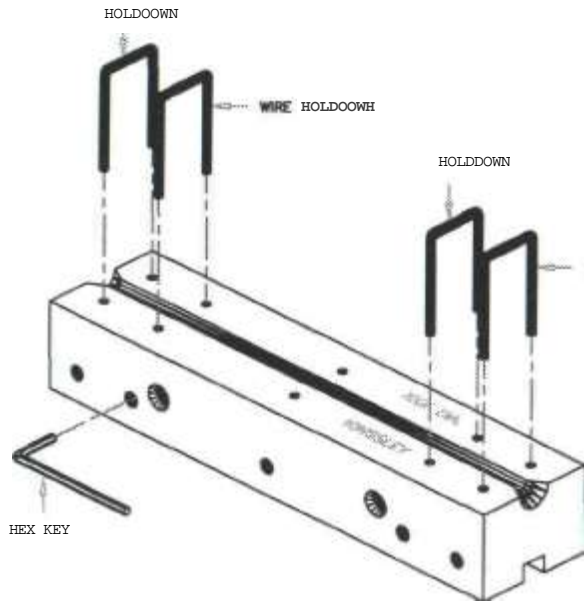

**CONFIGURATION
CONTINUOUS INCREMENTAL MARKING**

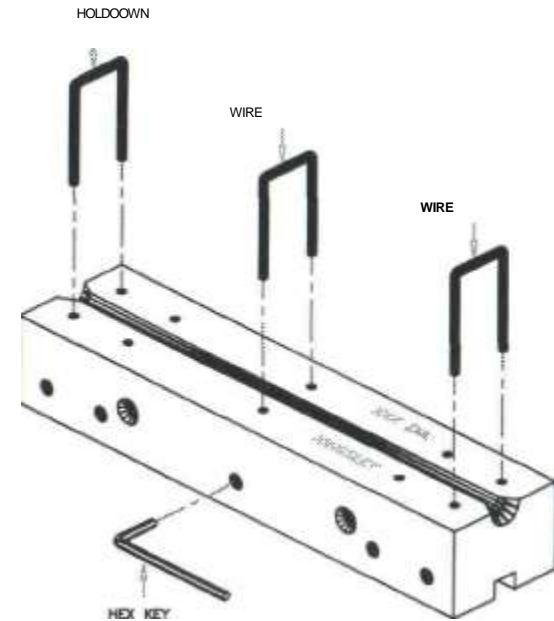

**CONFIGURATION
SIMULTANEOUS END MARKING**

WIRE FIXTURES ARE SUPPLIED IN CONFIGURATION AS ORDERED. **TO**

CHANGE CONFIGURATION:

1. USE HEX KEY TO LOOSEN ALL THE SET SCREWS RETAINING WIRE HOLDDOWNS.
2. REMOVE HOLDDOWN AND REINSERT AS SHOWN FOR DIFFERENT CONFIGURATION.
3. INSERT HOLDDOWNS UNTIL THE END IS FLUSH WITH THE BOTTOM OF THE WIRE FIXTURE BODY.
4. TIGHTEN ALL SET SCREWS. (DO NOT OVER TIGHTEN)

◆SEE OPPOSITE PAGE FOR PROPER SIZES..



A DIVISION OF ITW

V BLOCK WIRE HOLDING FIXTURES

(Do not use with Automatic Feed Machines)

PART NUMBER	CABLE O.D. RANGE
AN-8	0.255" (maximum wire O.D.)
AN-6	0.310" (maximum wire O.D.)
AN-4	0.370" (maximum wire O.D.)
AN-2	0.445" (maximum wire O.D.)
AN-1	0.495" (maximum wire O.D.)
AN-0	0.550" (maximum wire O.D.)
AN-00	0.610" (maximum wire O.D.)
AN-000	0.680" (maximum wire O.D.)
AN-0000	0.750" (maximum wire O.D.)

Note: All above fixtures are custom manufactured and require a four (4) week lead time.

Please contact our Customer Service Department for current pricing.

2538 Wisconsin Avenue
Downers Grove, IL. 60515
info@itwnorwood.com
www.itwnorwood.com

Phone: 1-800-626-3464 630-968-0646
Fax: 630-968-7672

11/2005